

Silen S Swimming pool



Single-stage centrifugal pump for water recirculation and filtering

Applications

Recirculation and filtering of water of medium swimming pools.
Very quiet-running (LWA 75dB).
Self-priming up to 4m.

Materials

Pump body, foot, impeller, seal mounting, diffuser, suction and discharge in technopolymer.
Pump shaft in AISI 431.
ESPA mechanical seal.
Motor casing in aluminium.
O-rings in NBR.

Equipment

Connection box V0 (self-extinguishing flame).
P2 capacitor (10.000h).
No cable, no plug.
Metric unions included (suction 50/63mm, discharge 50mm).

Motor

Asynchronous, 2 poles.
IP 55 protection.
Class F insulation.
1~: Thermal protection included.
Continuous operation.

Limitations

Maximum water temperature: 40° C.



Request for imperial unions (suction 1^{1/2}" / 2", discharge 1^{1/2}")

Hydraulic performance table

Model	I [A]			P1 [kW]		P2		c [µF]	*Pool volume [m ³]	l/min m ³ /h									Code	
	1~ 230V	3~ 230V	3~ 400V	1~	3~	[kW]	[HP]				40	80	120	160	215	265	325	400	1~230V	3~230V/400V
Silen S 60	3,7	2,4	1,4	0,8	0,8	0,44	0,6	16	90	mwc	13,6	13,2	12,6	10,9	6,7	-	-	-	203147	203151
Silen S 75	5,5	3,3	1,9	1,2	1,0	0,55	0,75	16	110		15,2	15	12,5	13,1	9,9	6	-	-	203148	203152
Silen S 100	6,0	3,8	2,2	1,4	1,2	0,75	1,0	16	125		16,9	16,5	16	15	12,9	10	5,9	-	203149	203153
Silen S 150	7,1	4,8	2,8	1,6	1,6	1,1	1,5	25	150		18,6	18,2	17,7	16,9	15,1	13	10	5,1	203150	203154

*Considering water circulation of 8 h/day

Dimensions and weights

Model	A	B	C	D	E	F	G	H	I	J	K	L	Kg
Silen S 60	495	211	170	225	2 1/4"	225	2 1/4"	308	159	Ø9	319	238	8,9
Silen S 75	495	211	170	225	2 1/4"	225	2 1/4"	308	159	Ø9	319	238	10,2
Silen S 100	495	211	170	225	2 1/4"	225	2 1/4"	308	159	Ø9	319	238	10,9
Silen S 150	495	211	170	225	2 1/4"	225	2 1/4"	308	159	Ø9	319	238	13,5

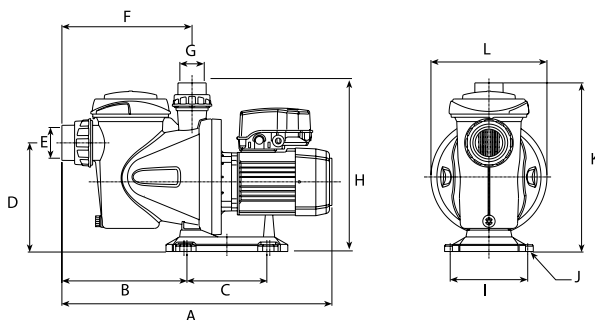

Performance curves at 2900 rpm

